



Industrial Inverter

The Gentec inverter systems, **OND2 SERIES**, provide safe, pure sine wave, reliable power to critical control equipment.

These inverters are "online" type, usually the load is fed by the inverter. In the unlikely event of an inverter failure, the static switch instantly transfers the load to the AC emergency supply. Then, power cuts to the load are avoided.



These true on-line inverters incorporate pulse width modulation (PWM) control combined with high frequency IGBT power transistors.

The system includes:

- an inverter (DC/AC converter);
- a static switch;
- a maintenance bypass switch (to isolate the system).

Typical customers include utilities and heavy industries.

BENEFITS

- » Designed especially to fulfill the needs of the industries and power companies substations;
- » Built to requirements;
- » Mature and proven technology;
- » Easy to maintain;
- » Life expectancy over than 25 years

SYSTEM FEATURES

- » Compatible with nonlinear loads;
- » Pure sine wave inverter;
- » Input/Output isolated;
- » 125Vdc or 250Vdc input;
- » Static switch 4 ms

OND2 Series

Control Unit

A microprocessor control unit ensures the PWM waveform generating, the synchronization and steady-state voltage regulation even when the inverter supplies non-linear loads. In addition, it ensure the measuring (voltmeters, ammeters, frequency meter) and the monitoring (extensive alarms system) of the inverter.

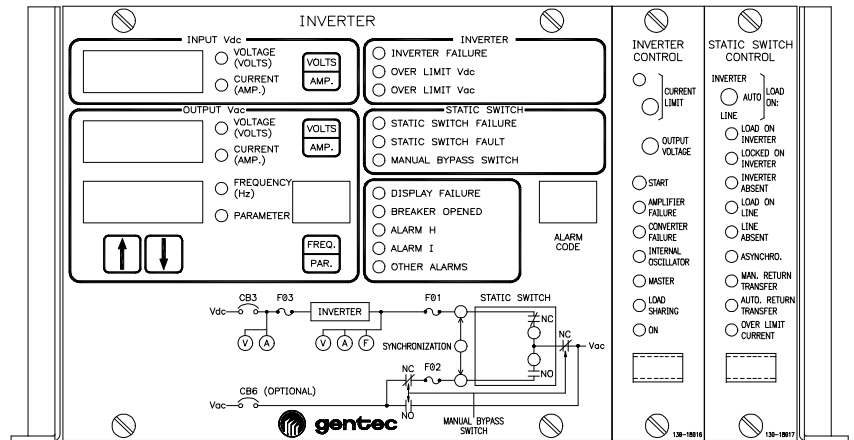

Control Unit

Bloc diagram

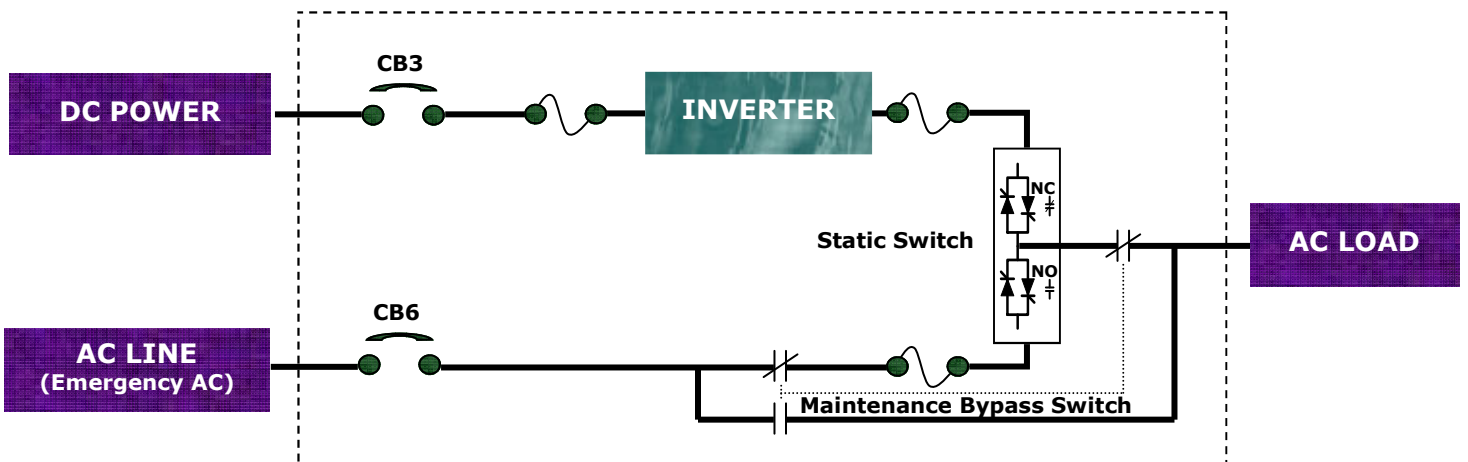

Model

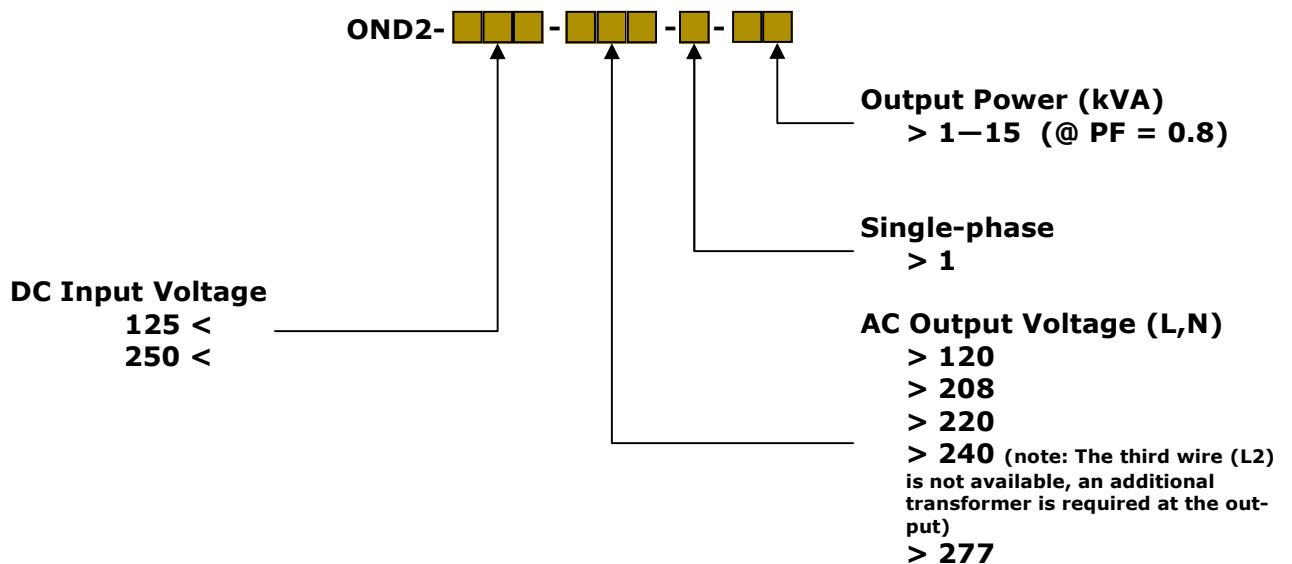

Configuration

The inverters are available according to the following configurations:

Regular Systems: Each system is composed of a single inverter system.

Master-Slave Systems: Each system is composed of two (2) redundant inverters operating in the following manner: one of these systems (inverter A) is the master and usually the unit which feeds the load. If it fails, the static switch (A) transfer the load to the second unit (inverter B) that will then supply the entire load. Subsequently, If inverter (B) fails, the static switch (B) will transfer the load to the AC emergency supply.

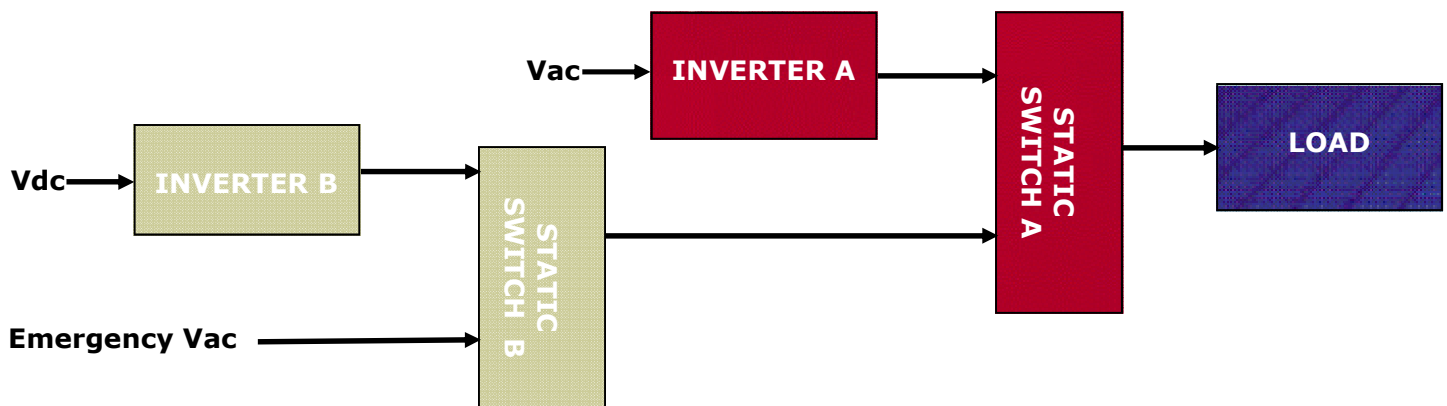

Master-Slave Configuration

Alarms and indicators

- inverter failure;
- low/high input voltage, Vdc;
- low/high output voltage, Vac;
- static switch failure;
- load on bypass supply;
- bypass supply absent;
- inverter out of synchronism with the bypass supply;
- maintenance bypass in "bypass" position

The alarms and indications are represented by LEDs on the microprocessor control unit, which are visible on the outside of the cabinet.

Alarm codes: the other alarms are indicated by alarm codes on the microprocessor control unit, which are also visible on the outside of the cabinet.

The alarms (or alarm codes) are associated with form "C" alarm contacts.

The alarm settings are easily adjustable in the field with the microprocessor control unit in parameter mode.

Characteristics	
DC INPUT	
Input Voltage	125Vdc or 250Vdc (range: 105-140Vdc or 210-280Vdc)
Protection	thermal magnetic circuit breaker, 2 poles
AC INPUT (Emergency AC)	
Protection	thermal magnetic circuit breaker, 1 pole
AC OUTPUT	
Voltage	120/208/220/240/277Vac – single phase (L,N) (note: for 240Vac, the third wire (L2) is not available, an additional transformer is required after the output)
Frequency	60Hz (optional 50Hz)
Output Power (at P.F. = 0.8)	1kVA to 15kVA
Power Factor	0.7 lagging (inductive loads) to 0.9 leading (capacitive loads)
Crest Factor	3.0 (peak current value/nominal RMS current)
Voltage Regulation	static: $\pm 0.5\%$ for 0-100% load variation dynamic: $\pm 10\%$ for 50% load variation, return at $\pm 5\%$ in less than 4 cycles
Frequency Regulation	$\pm 0.1\%$
Overload	125% for 10 min. / 150% for 10 sec.
Efficiency (full load)	$\geq 85\%$
Harmonic Distortion (THD)	2.5% max.
Cooling	- natural convection up to 3KVA - forced over 3KVA
STATIC SWITCH	
Transfer Time	4.0ms (typical)
Protection	semiconductor fuses
Maintenance Bypass Switch	included
Measuring Apparatus	
Digital Type	- DC voltmeter, range: 0-120%, accuracy: 0.1% - DC ammeter, range: 0-120%, accuracy: 1.0% - AC voltmeter, range: 0-120%, accuracy: 0.2% - AC ammeter, range: 0-120%, accuracy: 1.0% - frequency meter, range: 50 to 70 hz, accuracy: 0.5%
Environmental Specifications	
Operating Temperature	0 °C—40 °C (32°F—104°F)
Storage Temperature	20 °C—70 °C (-4°F—158°F)
Relative Humidity	5—95% at 40 °C (32°F) non-condensing
Audible Noise	60dBA max. measured at 1.0 meter (3 feet)
Altitude Derating	0% @ 0-1000 m (3280 feet)
Testing	
Dielectric Strength	CEI 255-5 (1977) (1500Vac, 1 minute) (700Vdc on alarm contacts and Vdc input) (optional: 2100Vdc on alarm contacts)
Surge Withstand Capability	Comply with ANSI/IEEE C37.90.1 (1989) («Surge Withstand Capability (SWC) testing»)
Dry Heat test	Comply with CEI 68-2-2 (1974)
Damp Heat test	Comply with CEI 68-2-3 (1974)
Electromagnetic Compatibility (EMC) - immunity	Comply with CEI 801-3 (1984)
Vibration	Comply with CEI 255-21-1 (1988)

Cabinet	
Dimensions (HxLxD)	cabinet A1: 1800x600x600mm (70.9 x 23.6 x 23.6inches), freestanding cabinet cabinet A2: 2000x800x800mm (78.7 x 31.5 x 31.5inches), freestanding cabinet (depth: additional clearance of 144mm is required behind for ventilation)
Material	Cold laminated steel 2.0 – 3.0mm outside panels Cold laminated steel 3.0mm inside frame
Cabinet Type	NEMA1 / IP20 (NEMA2 / IP23 optional)
Color & Finish	Gray ANSI61 (other colors and finish on demand)

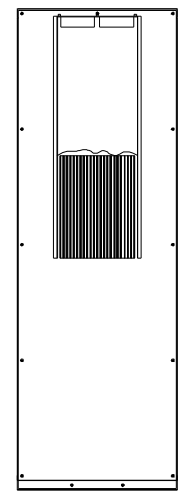
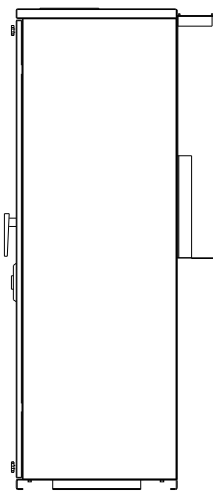
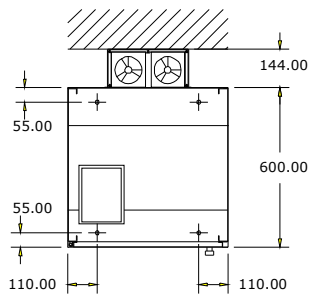
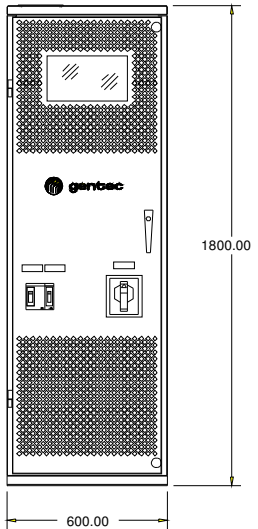

Cabinet A1, power ≤7.5KVA
(note: natural convection up to ≤3KVA)

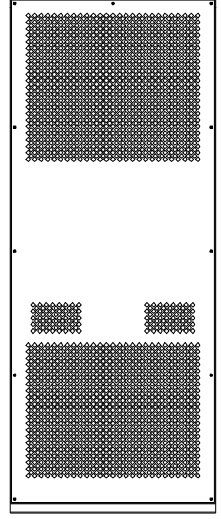
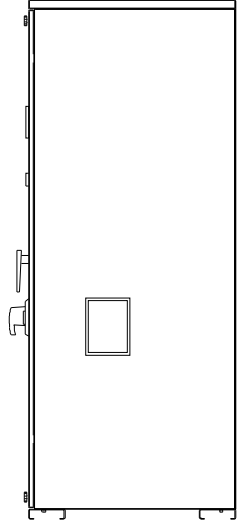
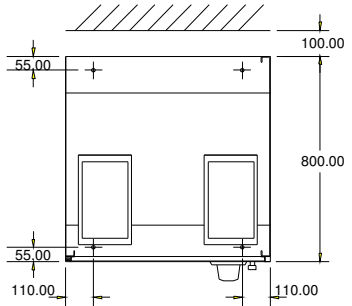
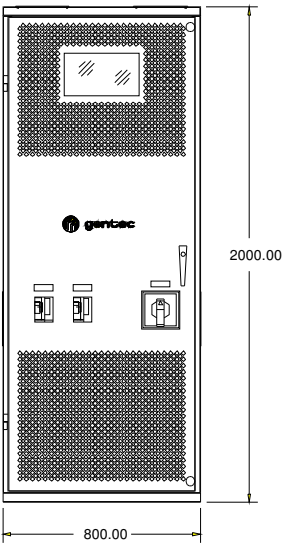

Cabinet A2, power >7.5KVA

